



Instruction manual



2026-06-02

Cooking range solid top gas with electric static oven STPST 780/21 GE

www.rmgastro.com



TABLE OF CONTENTS

1. DECLARATION OF CONFORMITY	3
2. TECHNICAL DATA	3
3. TABLE OF GASES FOR WHICH THE PRODUCT IS INTENDED	3
4. LOCATION ELECTRIC	4
5. LOCATION GAS	4
6. SAFETY MEASURES FOR FIRE PROTECTION	4
7. INSTALLATION	5
8. THERMAL OUTPUT CHECK	5
9. CONNECTING GAS CONNECTION HOSE	5
10. LIQUID GAS CONNECTION	5
11. CONNECTING THE ELECTRICAL CABLE TO THE NETWORK	6
12. CHECK DEVICE SETTINGS FOR GAS TYPE	6
13. CHECK OF THE DEVICE SETTINGS FOR THE TYPE OF GAS	8
14. CHECK OF THE DEVICE SETTINGS FOR THE TYPE OF GAS THAT	11
15. CHECKING THE GAS SETTING OF THE APPLIANCE (OVEN)	12
16. INSTRUCTIONS FOR USE	13
17. INSTRUCTIONS FOR USE	14
18. CLEANING AND MAINTENANCE	17

1. DECLARATION OF CONFORMITY

Decree of the Ministry of Health of the Czech Republic no. 38/2001 Coll. of 19 January 2001 Regulation (EC) No 1907/2006 - Registration, Evaluation, Authorisation and Restriction of Chemicals (REACH) Regulation of the European Parliament and Council Regulation (EC) no. 1935/2004 of 27 October 2004

The products meet the requirements of §26 of Act No.258/2000 as amended. The products meet the requirements of RoHS Directive 2015/863/EU, 10/2011, 517/2014, 2015/1094, 2015/1095.

Attention, the manufacturer gives up any responsibility in case of direct and indirect damage that is related to poor installation, incorrect intervention or adjustments, insufficient maintenance, incorrect use and which are eventually caused by other causes than the points referred to in the conditions of sale. This appliance is intended only for professional use and must be operated by qualified persons. Parts that have been secured by the manufacturer or authorized worker after the setting rebuild.

2. TECHNICAL DATA

The label with technical data is located on the side or back panel of the device. Please read the wiring diagram and all the following information in the attached manual before installation.

Net Width [mm]	Net Depth [mm]	Net Height [mm]	Net Weight [kg]	Power electric [kW]
800	900	900	122.60	6.300
Loading	Power gas [kW]	Oven Type	Oven power electric [kW]	Oven size
400 V / 3N - 50 Hz	19.100	electrical static	6.30	GN 2/1

The maximum and reduced nominal heat input in kW is related to the Hi of the gas used. If the product is connected to LPG, the gas cylinder must be in sufficiently ventilated rooms.

3. TABLE OF GASES FOR WHICH THE PRODUCT IS INTENDED

Execution	Product Category	Connection overpressures (mbar)	Used gas	Country of destination
A1	I2E	20	G20	DE, NL, PL, RO
A1	I2ELL	20, 20	G20,G25	DE
A1	I2E+	20/25	G20/G25	BE, FR
A1	I2H	20	G20	AT, BG, CH, CZ, DK, HR, EE, ES, FI, GB, GR, IE, IT, LT, LV, NO, PT, RO, SE, SI, SK, TR, LU, CY, FR
A1	I3B/P	30	G30	BG, CY, CZ, DK, GB, HR, EE, FI, FR, GR, HU, IT, LT, LV, MT, NL, NO, RO, SE, SI, SK, TR
A1	I3B/P	50	G30	AT, DE, CZ, CH, FR, SK
A1	I3P	37	G31	BE, CH, CZ, ES, GB, GR, IE, RO, SI, SK, FR, NL, PT, HR, IT, LT, PL, TR
A1	I3+	28-30/37	G30/G31	BE, CH, CY, CZ, EE, ES, FR, GB, GR, IE, IT, LT, PT, SI, SK, TR
A1	I12E3B/P	20, 50	G20, G30	DE, PL, RO
A1	I12ELL3B/P	20, 20, 50	G20, G25, G30	DE
A1	I12E+3+	20/25, 28-30/37	G20/G25, G30/G31	BE, FR

Execution	Product Category	Connection overpressures (mbar)	Used gas	Country of destination
A1	I12H3B/P	20, 30	G20, G30	BG, CZ, GB, DK, HR, EE, FI, GR, IT, LT, LV, NO, RO, SE, SI, SK, TR, CY, FR
A1	I12H3B/P	20, 50	G20, G30	AT, CH, CZ, FR, SK
A1	I12H3P	20, 37	G20, G31	CH, CZ, ES, GB, GR, IE, RO, SI, SK
A1	I12H3+	20, 28-30/37	G20, G30/G31	CH, CY, CZ, EE, ES, GB, GR, IE, IT, LT, PT, SK, SI, TR

4. LOCATION ELECTRIC

For the correct operation and placement of the appliance, it is necessary to observe the following all prescribed standards for the given market. Unpack the device and check that the device has not been damaged during transport. Place the device on a horizontal surface (maximum unevenness up to 2°). Small unevenness can be leveled with adjustable feet. If the device will be placed in such a way that it will be in contact with the walls of the furniture, these must withstand a temperature of up to 60°C. Installation, adjustment, commissioning must be performed by a qualified person who is authorized to perform such operations, according to applicable standards. The device can be installed separately or in series with devices of our production. A minimum distance of 10 cm from flammable materials must be observed. In this case, it is necessary to secure the appropriate modifications to ensure the thermal insulation of the combustible parts. The appliance must only be installed on a non-flammable surface or against a non-flammable wall. **Parts of the appliance provided by the manufacturer. or his representative, the worker performing the installation may not rebuild the product.**

5. LOCATION GAS

For the correct activity and location of the appliance, it is necessary to observe all directives and standards of the country. Expand the device and check that the device has not been damaged during transport. Place the device on the horizontal surface (maximum inequality up to 2 °). Minor inequalities can be balanced with regulated legs. If the device is located in contact with the walls of the furniture, they must withstand temperatures up to 60 ° C. Installation, adjustment, commissioning must be carried out by a qualified person who is authorized for such acts, according to valid standards. The device can be installed separately or in a series with our production devices. It is necessary to follow a minimum distance of 10 cm from flammable materials. In this case, it is necessary to ensure the appropriate adjustments to ensure the thermal insulation of flammable parts. The appliance must only be installed on a non -flammable surface or at a non -flammable wall. **The smallest required air flow from the outdoor space for appliances in design and in the range of 5-20 m3/h, depending on the type of appliance. It depends on the installation regulations for the country of destination. Components of the appliance secured by the manufacturer. Or his representative must not rebuild the worker's installation of the product. The device must be installed in a suitably ventilated environment.**

6. SAFETY MEASURES FOR FIRE PROTECTION

- the appliance may only be operated by adults
- the appliance may be used safely in accordance with applicable market standards:

Fire protection in spaces with special risk or danger

Protection against the effects of heat

- the appliance must be placed so that it stands or hangs firmly on a non-combustible surface

Objects of flammable substances must not be placed on the appliance at a distance less than a safe distance from it (the smallest distance between the appliance and flammable substances is 10 cm).

Table: degree of flammability of building materials included in st. flammability of substances and products

Degree of flammability	Building materials
A - non-flammable	granite, sandstone, concrete, brick, ceramic tiles, plaster
B - Not easily flammable	Acumin, Heraclitus, Lihnos, Itaver
C1 - highly flammable	wood, hardwood, plywood, hard paper, umakart
C2 - moderately flammable	chipboards, solodur, cork boards, rubber, flooring
C3 - Highly flammable	wood fiber boards, polystyrene, polyurethane, PVC

- information on the degree of flammability of common building materials is given in the table above. Appliances must be installed in a safe manner. During installation, the relevant design, safety and hygiene regulations must also be respected:
- fire safety of local appliances and heat sources
- fire protection in areas with special risk or danger
- protection against the effects of heat

7. INSTALLATION

Important: The manufacturer does not provide any warranty for defects arising as a result of incorrect use, failure to follow the instructions contained in the attached user manual and mishandling of appliances. Installation, modification and repair of appliances for large kitchens, as well as their dismantling due to possible damage to the gas supply, can only be carried out on the basis of a maintenance contract, this contract can be concluded with an authorized dealer, while technical regulations and standards and regulations must be observed regarding installation, electrical supply, gas connection and work safety. Technical instructions for installation and adjustment, for use by specialized technicians ONLY. The instructions that follow refer to a technician qualified for installation to carry out all operations in the most correct manner and according to the applicable standards. Any activity related to regulation etc. must only be performed with the device disconnected from the network. If it is necessary to keep the appliance under voltage, the utmost care must be taken. The type of appliance for extraction is declared on the nameplate, it is an A1 appliance.

8. THERMAL OUTPUT CHECK

Appliances must be checked to verify their thermal power input: The heat output is marked on the label or can be found in this manual. It is necessary to verify first if the appliance is made for the same type of gas to be used and therefore if the label corresponds to the gas type label to be used. To convert to another type of gas, it is necessary to check if the type of gas marked corresponds which is recommended in this manual. The pressure is measured by the pressure gauge of the necessary sensitivity. The pressure gauge is connected to the appropriate location, so it is necessary to unscrew the screw with an airtight cap and connect the pressure gauge. After the measurement, it is necessary to screw the screw back and check its tightness.

9. CONNECTING GAS CONNECTION HOSE

The gas must be connected by a tube with a maximum length of 1.5 meters of galvanized steel, copper or flexible steel hose in accordance with the applicable ground standards. Each device must have a closable tap at the inlet to easily stop the gas supply. After installing the device, we must check any gas leaks. Never check the leaks with an open fire. Materials that do not cause corrosion, for example, a soap water solution, must be used to check gas leakage. The devices underwent a thorough inspection of the manufacturer, the data on the type of gas, pressure and type of the device are listed on the label with characteristics. LPG bottles must be equipped with a controller that corresponds to the gas pressure on the equipment label in accordance with the applicable country's legislation.

10. LIQUID GAS CONNECTION

Connecting the appliance to the gas distribution system must be made by a steel or copper hose suitable for valid national requirements. This must be checked regularly and replaced as needed. Each appliance

must be equipped with a closing tap and a quick slip. The quick slip must be freely accessible and within range of the device. After the installation, it is necessary to check that there is no gas leakage. To determine leaks we use soapy water or detection sprays to determine possible leaks. Do not use corrosion-causing substances! All our appliances are carefully inspected. The type of gas, pressure and designation of the relevant category are listed on the production label. Connection to liquid gas: The pressure for liquid gas connection must be 28 or 30 mbar for propane/butane and 37 mbar for propane. It is necessary to check the label, measure the pressure and check the parameters of the installed nozzles with the required nozzle parameters according to the manufacturer's requirements. If the pressure is less than 25 mbar or greater than 37 mbar must not be connected to the appliance. Natural gas connection: The pressure when connecting to methane must be 18 or 20 mbar. It is necessary to check the label, measure the pressure and check the parameters of the installed nozzles with the required nozzle parameters according to the manufacturer's requirements. If the pressure is less than 15 mbar or higher than 22.5 mbar must not be connected to the appliance.

11. CONNECTING THE ELECTRICAL CABLE TO THE NETWORK

Installation of the electrical supply - this supply must be separately secured. At with the corresponding circuit breaker of rated current depending on the power input of the installed device. Check the power consumption of the device on the production label on the back panel (or side) of the device. The connected ground wire must be longer than the other wires. Connect the device directly to the network, it is necessary to insert a switch between the device and the device with a minimum distance of 3 mm between the individual contacts, which corresponds to the applicable standards and load. The earth supply (yellow-green) must not be interrupted by this switch. Connect the device to the mains if the socket has adequate protection. In any case, the supply cable must be located so that it does not reach a temperature of 50 degrees higher than the environment at any point. Before the appliance is connected to the network, it is necessary to first make sure that:

- the supply circuit breaker and the internal distribution can withstand the current load of the appliance (see matrix label)
- the distribution board is equipped with effective grounding according to the standards of the relevant market and the conditions given by law
- the socket or switch in the supply is easily accessible from the appliance
- the electrical supply to the device must be made of oil-resistant material

We disclaim any responsibility in the event that these standards are not respected and in the event of a violation of the above principles. Before first use, you must clean the device, see chapter "cleaning and maintenance". The appliance must be grounded using a screw with a grounding mark.

- Do not insert the plug of the power supply into the electrical outlet. sockets and do not pull out the zel. sockets with wet hands and pulling on the power cord!
- Do not use extension cords or multiple sockets.
- **The mains connection point must have a maximum of the following impedance: $Z_{MAX} = 0.042 + j 0.026 \Omega$ for the phase conductors and $0.028 + j 0.017 \Omega$ for the neutral conductor.**

12. CHECK DEVICE SETTINGS FOR GAS TYPE

Our appliances are certified and regulated for natural gas (see type plate). Conversion or adaptation to a different type of gas must only be carried out by an authorized technician. Nozzles for different types of gas are in a bag packed with the boiler and are marked in hundredths of mm (technical data table).

MODEL	VOLTAGE (V/Hz)	BURNERS	OVEN (kW)	DIMENSIONS (cm)
STPST 7120/21 GE	400/3N/50	1x 6,6 kW + 3x 8,5 kW + 1x 4 kW	6,3	120x73x90 h
STPST 7120/21 G	-	1x 6,6 kW + 3x 8,5 kW + 1x 4 kW	6 (gas)	120x73x90 h
STPST 780/21 GE	400/3N/50	1x 6,6 kW + 1x 8,5 kW + 1x 4 kW	6,3	80x73x90 h
STPST 780/21 G	-	1x 6,6 kW + 1x 8,5 kW + 1x 4 kW	6 (gas)	80x73x90 h
STT 780/21 GE	400/3N/50	1x 10,8 kW	6,3	80x73x90 h
STT 780/21 G	-	1x 10,8 kW	6 (gas)	80x73x90 h
STPST 7120/31 GE	400/3N/50	1x 6,6 kW + 3x 8,5 kW + 1x 4 kW	8,7	120x73x90 h
STPST 7120/31 G	-	1x 6,6 kW + 3x 8,5 kW + 1x 4 kW	10,5 (gas)	120x73x90 h
Diameter of pots				
4 kW - min. 14 cm; max. 38 cm				
8,5 kW - min. 14 cm; max. 50 cm				

Data	Type of gas					
Burner 8,5 kW	G25.1 25 mbar	G2.350 13 mbar	G27 20 mbar	G31 30-37 mbar	G31 37 mbar	G31 50 mbar
Diameter 1/100mm	240	315	250	145	140	130
air control settings (mm)	3,5	open	3,5	open	open	open
Consumption	1,044 m3/h	1,249 m3/h	1,097 m3/h	0,660 kg/h	0,660 kg/h	0,660 kg/h
Burner 10,8 kW						
Diameter 1/100mm	260	350	280	160	155	140
air control settings (mm)	390	750	390	90	85	80
Consumption	1,327	1,588	1,394	0,839	0,839	0,839
Burner 6,6 kW						
Diameter 1/100mm	205	270	220	125	115	110
air control settings (mm)	240	360	270	70	75	60
Consumption	0,811	0,970	0,852	0,513	0,513	0,513
Burner 6 kW (oven)						
Diameter 1/100mm	195	260	205	125	115	110
air control settings (mm)	13	13	13	13	13	13
Consumption	0,737 m3/h	0,882 m3/h	0,774 m3/h	0,466 kg/h	0,466 kg/h	0,466 kg/h
Burner 4 kW						
Diameter 1/100mm	240	315	250	145	140	130
air control settings (mm)	closed	closed	closed	open	open	open
Consumption	1,044	1,249	1,097	0,660	0,660	0,660
Pilot burner						
Diameter 1/100mm	27	36	27	19	19	19

Data	Type of gas						
Burner 8,5 kW	G30 28-30 mbar	G30 37 mbar	G30 50 mbar	G20 20 mbar	G25 25 mbar	G25 20 mbar	G20 25 mbar
Main burner diameter 1/100mm	145	140	130	215	225	245	205
Air kontrol _settings (mm)	open	open	open	3,5	3,5	3,5	3,5
Gas Consumption	0,670 kg/h	0,670 kg/h	0,670 kg/h	0,899 m3/h	1,046 m3/h	1,046 m3/h	0,899 m3/h
Burner 10,8 kW							
Main burner diameter 1/100mm	160	155	140	245	255	270	230
Air kontrol _settings (mm)	90	85	80	330	360	390	300
Gas Consumption	0,852	0,852	0,852	1,143	1,329	1,329	1,143
Burner 6,6 kW							
Main burner diameter 1/100mm	125	115	110	190	200	215	180

Air kontrol _settings (mm) By-pass screw adjustment	70	75	60	210	240	270	180
Gas Consumption	0,520	0,520	0,520	0,698	0,812	0,812	0,698
Burner 6 kW (oven)							
Main burner diameter 1/100mm	125	115	110	180	195	205	175
Air kontrol _settings (mm)	13	13	13	13	13	13	13
Gas Consumption	0,473 kg/h	0,473 kg/h	0,473 kg/h	0,635 m3/h	0,738 m3/h	0,738 m3/h	0,635 m3/h
Burner 4 kW							
Main burner diameter 1/100mm	145	140	130	215	225	245	205
Air kontrol _settings (mm)	open	open	open	closed	closed	closed	closed
Gas Consumption	0,315	0,315	0,315	0,899	1,046	1,046	0,899
Pilot burner							
diameter 1/100mm	19	19	19	27	27	27	27

13. CHECK OF THE DEVICE SETTINGS FOR THE TYPE OF GAS

Our appliances are certified and regulated for natural gas (see type plate). Conversion or adaptation to a different type of gas must only be carried out by an authorized technician. Nozzles for different types of gas are in a bag packed with the stove and are marked in hundredths of mm.

Replacing the torch nozzles:

It is necessary to proceed as follows:

- 1) Remove the grate
- 2) flame sprayer
- 3) burner body
- 4) food container
- 5) Unscrew the nozzle with a wrench and replace it with the one required according to the type of gas. Install in reverse order. Make sure that the individual parts fit together thoroughly
- 6) Air regulation is always open according to the „NOZZLE CHART“ table

Replacement and regulation of the pilot burner:

- 1) Adjust the pilot burner by loosening the lock nut with a wrench
- 2) Then use the key to either loosen or tighten the nozzle

Important:

After the appliance has been adjusted to a different type of gas, it is necessary to mark the gas change on label of the appliance and perform the following steps:

- Check for possible gas leaks
- Check the ignition and flame of the main burner
- Check the flame of the main burner for min. performance „SPORO“

Flame adjustment at reduced power „SPORO“

Adjust the flame when the tap is set to reduced power „SPORO“ by means of the screw in the tap body (pos. 1, fig. 5) next to the tap shaft.

To adjust, proceed as follows:

- Remove the control knob (pos. 1, fig. 4) by pulling it towards you.
- There is an adjustment hole next to the tap shaft, adjust the flame with a flat head screwdriver

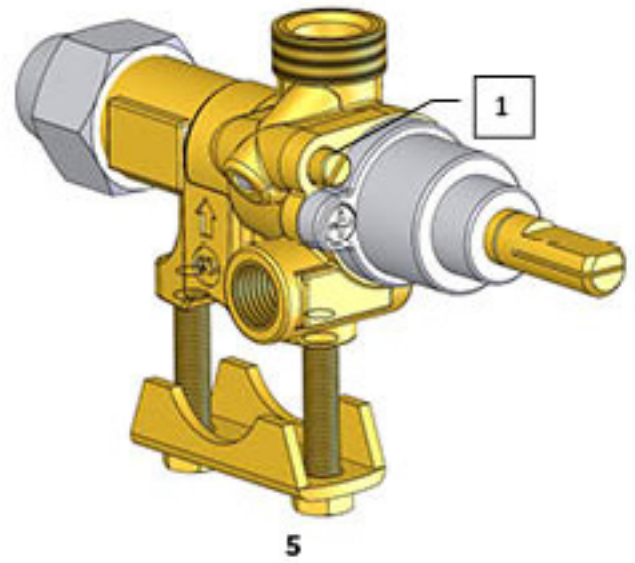
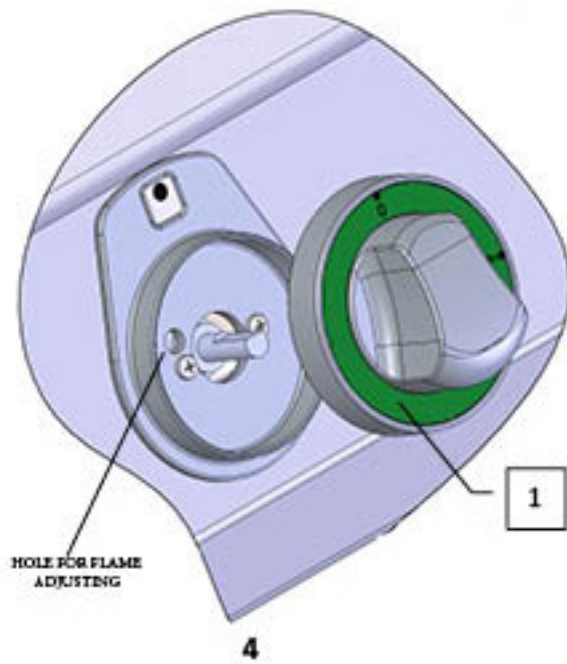

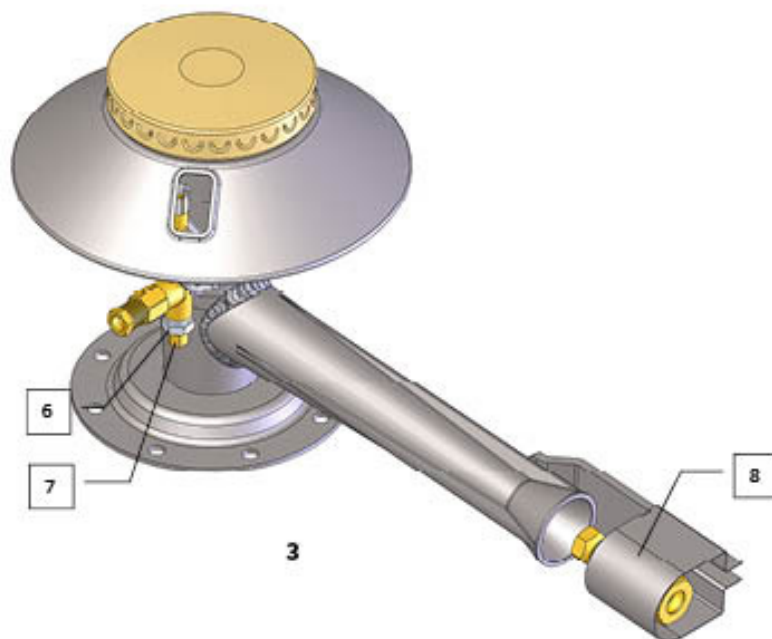
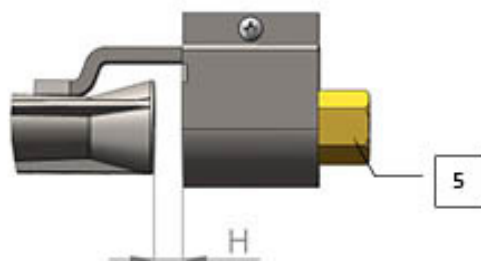
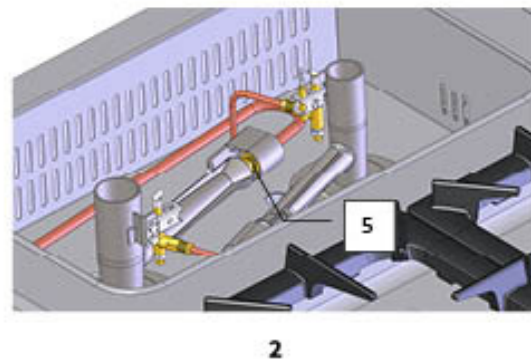
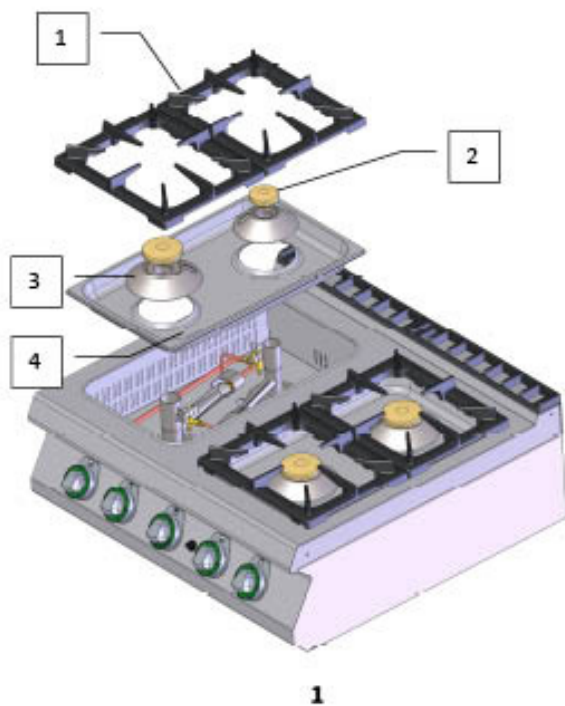

14. CHECK OF THE DEVICE SETTINGS FOR THE TYPE OF GAS THAT

Replacement of nozzles and adjustment of pilot burner:

The following procedure should be followed:

Pilot burner:

- 1) Unscrew the nut as shown in Figure 6 item 4.
- 2) Remove the copper supply pipe from the pilot burner (Fig. 6, pos. 5).
- 3) Unscrew nozzle from pilot burner and replace with desired nozzle per "Nozzle Table".
- 4) Reinstall the copper tube from the pilot burner and tighten it with the nut Fig. 6, item 4.

main burner nozzle:

- 1) unscrew the nozzle (fig. 6, pos. 3)
- 2) replace with the required nozzle according to the "Nozzle table"

Important:

After the appliance has been adjusted to a different gas type, the gas change must be marked on the the appliance label and perform the following steps:

- Check for any gas leaks.
- Check the ignition and flame of the main burner
- Check the flame of the main burner for minimum output "SPORO"

Adjust flame at reduced output "SPORO"

Adjust the flame when the tap is set to reduced power "SPORO" with the screw in the tap body (pos. 1, fig. 5) next to the tap shaft.

To adjust, proceed as follows:

- Remove the control knob (pos. 1, fig. 4) by pulling it towards you.
- There is an adjustment hole next to the tap shaft, adjust the flame with a flat head screwdriver

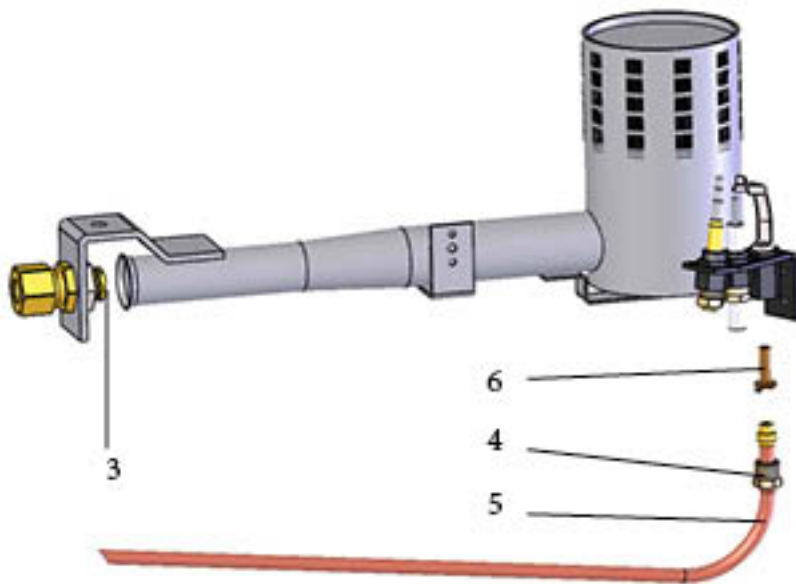

3) Nozzle of main burner

4) Unscrew nut

5) Unmount gas supply copper pipe from pilot nozzle.

6) Replace pilot nozzle for another by the desired diameter

15. CHECKING THE GAS SETTING OF THE APPLIANCE (OVEN)

Our appliances are certified and regulated for natural gas (see technical label). Conversion or modification to other types of gas must be carried out by authorised personnel. The nozzles for the different types of gas are in the bag supplied with the gas cooker and are marked in hundredths of mm (pipe technical data table).

Instructions for use: it is essential that you familiarise yourself with the gas cooker:

The main burner

- 1) Open the oven door and remove the cover plate. (false oven bottom).
- 2) Remove the main burner cover (Fig. 2).
- 3) Referring to the illustration (fig. 3), unscrew the nozzle from the main burner and replace it with the nozzles shown in the "TECHNICAL DATA" table.
- 4) Adjust the air supply for the appropriate gas according to the table "TECHNICAL DATA".

Pilot burner

- 1) Unscrew the nut according to Fig. 5, pos. 1
- 2) Remove the copper supply pipe from the pilot burner.
- 3) Unscrew the nozzle from the main burner according to Fig. 5, item 2 and replace the nozzles according to the table "TECHNICAL DATA OF THE BURNER".
- 4) Reinstall the copper tube on the pilot burner and secure it with the nut as shown in Figure 5, item 1.

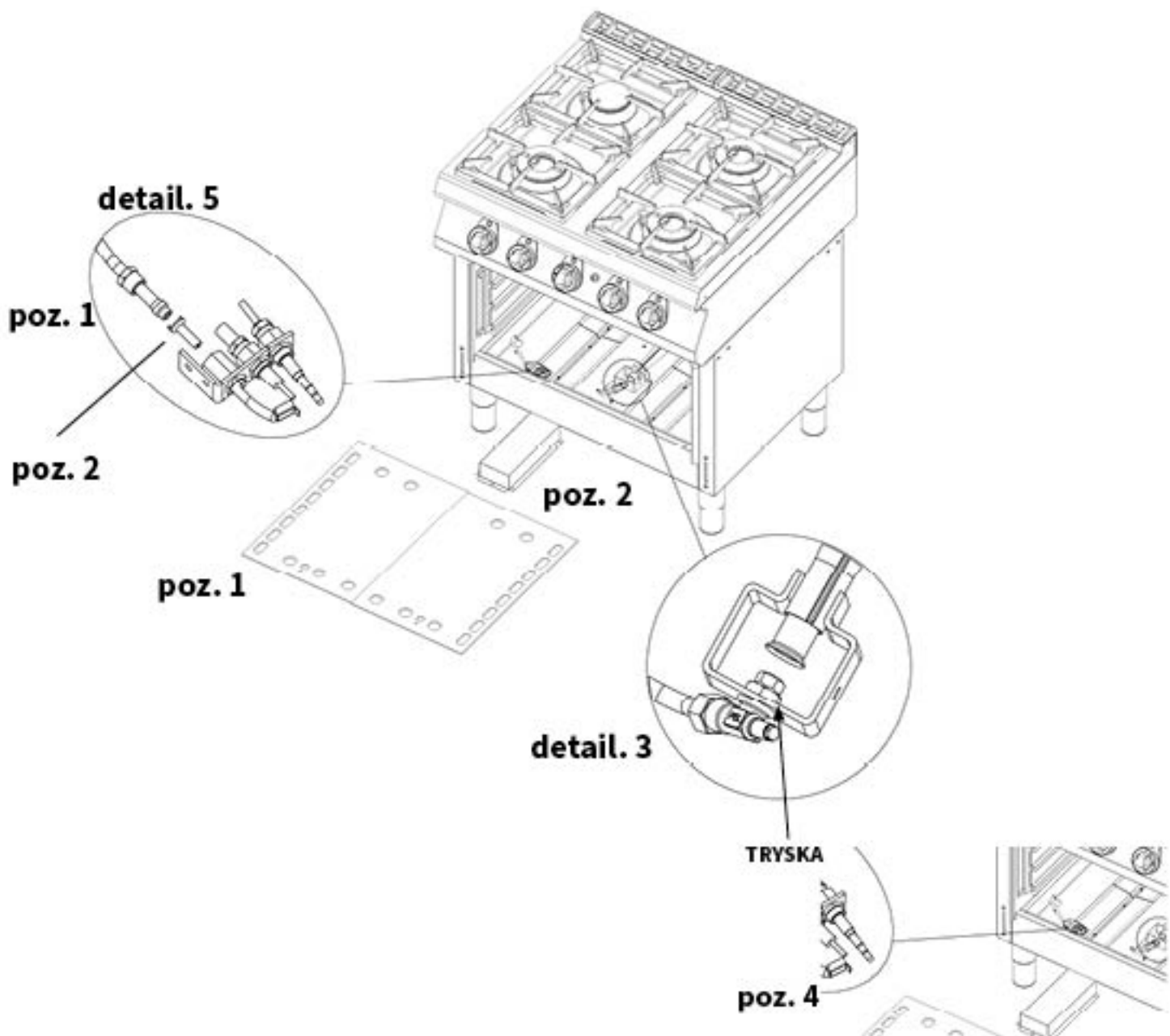

16. INSTRUCTIONS FOR USE

Attention! Before using the appliance, the protective film must be removed from the entire surface and then washed well with water and dish detergent, then wiped with a damp cloth.

Ignition and burner control

After pressing and turning the control knob of the respective burner to position 1, light the pilot burner. After lighting the pilot burner, keep the knob pressed for approx. 30 seconds to heat the thermal fuse. If the flame goes out, repeat the procedure.

To light the burner at full power, turn the knob to position 2.

To set the "SPORO" energy saving mode, lightly press the knob and turn to position 3.

Switch to standby mode by turning the knob to the right to position 1.

To turn the burner off, lightly press the knob and turn to position "0".



17. INSTRUCTIONS FOR USE

Attention! Before you start using the device, it is necessary to remove the protective films from the entire surface, then wash it well with water and dish soap, and then wipe it with a damp cloth.

Burner ignition and power regulation:

Put the tap control knob of the relevant burner (1) in the "main burner ignition" position and then press and hold it, press the piezo igniter knob (1) several times until the burner ignites. After lighting the burner, keep button number (1) pressed for a few seconds until the thermal fuse heats up, then release the button. If the flame goes out, repeat the whole process.



- ① BURNER CONTROL KNOB
- ② PIEZZO LIGHTER

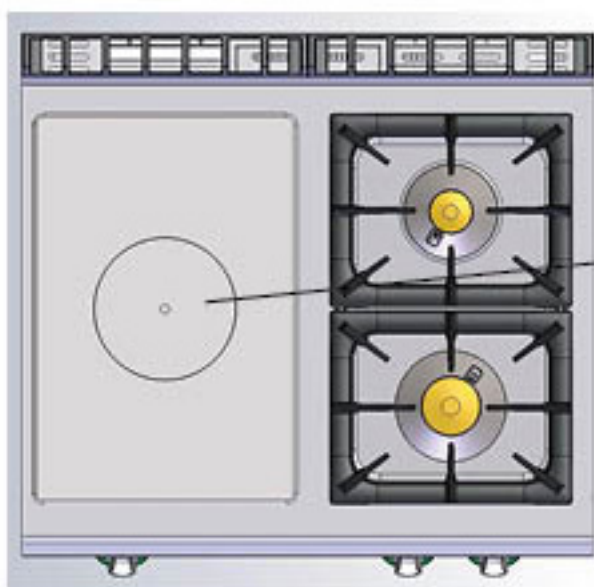
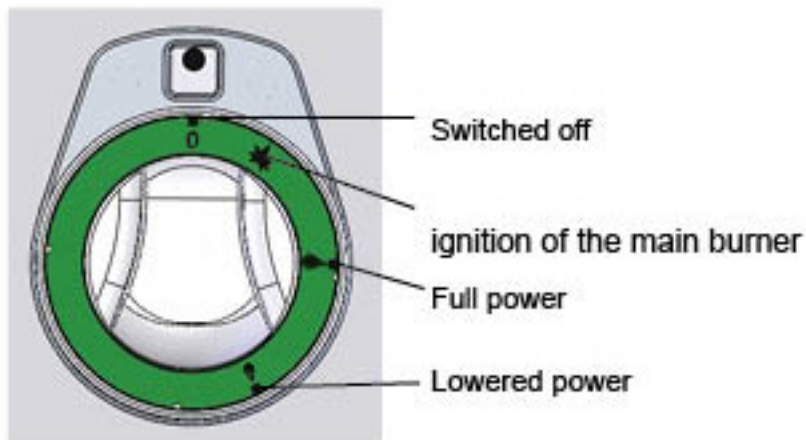

To visually inspect the pilot burner, remove the center of the plate with the "hook" included in the package.

Stationary oven control

Use the stationary oven switch to choose whether to bake with the upper and lower oven elements (position 1), the lower oven elements only (position 3) or the upper oven elements only (position 2). This is indicated by green lights. Use the control knob on the stationary oven to set the desired temperature. The operation of the heating elements is indicated by white lights. When they go out, the oven is heated to the desired temperature. Switch off the oven by turning both knobs to the "0" position.

Controlling the gas oven

To light and adjust the oven burner:

To light the oven, open the oven door, turn the knob to the ignition mark, hold the knob down, then press the piezzo ignition button repeatedly until the gas ignites. Use the hole in the bottom of the oven to check the flame, release the knob after approximately 10 seconds. If the pilot flame goes out, the whole opera-

tion must be repeated. When the knob is turned to the position to light the pilot flame, the main burner goes out and the pilot flame remains burning. To light the main burner, turn the knob to the left and set the desired temperature. To turn the oven completely off, turn the control knob to the "0" position.

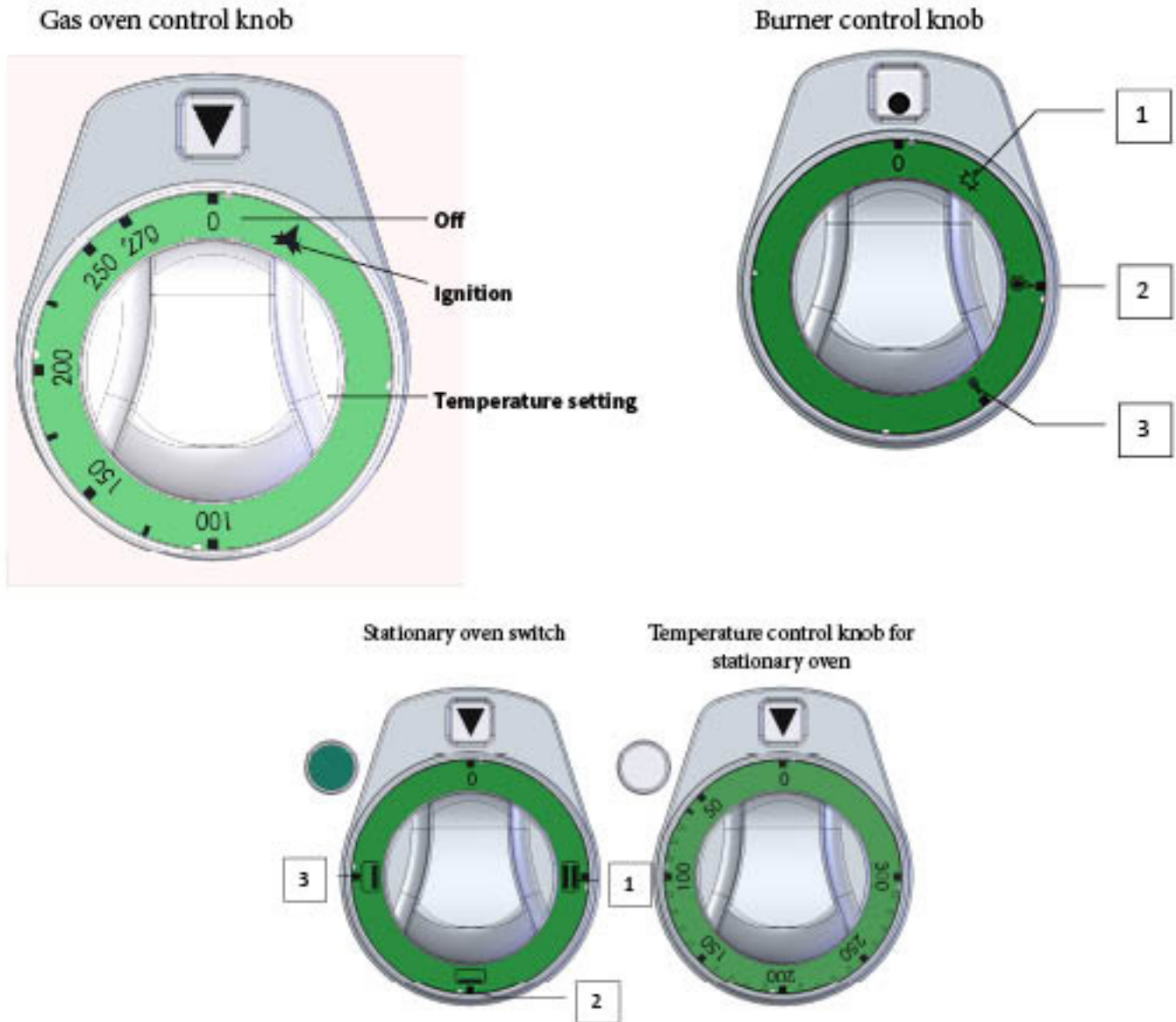

NOTICE FOR USE – FOR GAS OVENS

A gas oven is a static oven with the heat source located in the lower part.

Heating occurs through natural heat circulation without forced convection of hot air.

For this reason, uneven temperature distribution may occur during certain types of cooking, especially:

higher temperature near the bottom and around the edges of the oven,
faster heat impact on the edges of the gastronorm container,
restricted circulation of warm air.

When baking dishes in a GN (gastronorm) container, the container itself may limit the natural circulation of hot air around the food, which can result in the edges of the dish being exposed to more heat than the center. This characteristic is due to the design and principle of gas static heating and is not a manufacturing defect.

RECOMMENDED USE:

baking, stewing
baking pastries
keeping food warm

18. CLEANING AND MAINTENANCE

It is recommended to have the device checked with a specialist service at least once a year. All the interventions in the device can only be carried out by a qualified person who has the authorization to do so. **CAUTION!** The device must not be cleaned with direct or pressure water. Clean the equipment daily. Daily maintenance extends the life and efficiency of the equipment. Always turn off the main inlet to the device. Wash the stainless steel parts with a damp cloth with a detergent without coarse particles and wipe dry. Do not use abrasive or corrosive cleaning agents. Attention! Before using the device, it is necessary to remove the protective foil from the entire surface, and then wash it well with water with detergent, and then wipe it with a damp cloth. **ALERT!** The warranty does not apply to all consumables subject to normal wear (rubber seals, bulbs, glass and plastic parts, etc.). The warranty also does not apply to the device if the installation is not carried out in accordance with the instructions - an authorized worker according to the corresponding standards and if the equipment was unprofessionally manipulated (interventions in the internal equipment, etc.) or were operated by unhappy staff and contrary to the instructions for use, further The warranty does not apply to damage by natural effects or other external intervention. **Required service organization 2 times a year. After the lifetime, the shipping packaging and equipment are submitted to the collection, according to the regulations on waste management and hazardous waste.**